

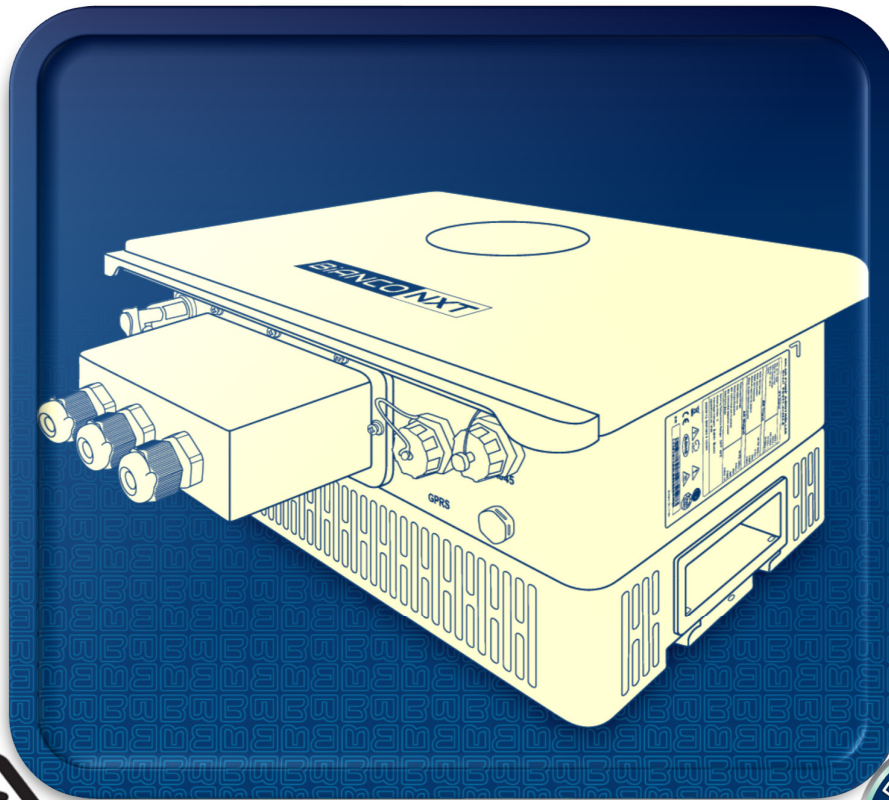

# **NXT-FLEXI SOLAR**

## QUICK SETUP GUIDE

- |                         |                  |
|-------------------------|------------------|
| <b>NXT FlexiSolar22</b> | <b>PN 811612</b> |
| <b>NXT FlexiSolar40</b> | <b>PN 811613</b> |
| <b>NXT FlexiSolar75</b> | <b>PN 811614</b> |



## Important Note



This Quick Guide has been produced to aid setup and commissioning. It is **NOT** intended to replace the primary User and Installation manual.

The two documents should be read in conjunction with each other

# 1. Contents

1. Contents .....	2
2. Range Introduction .....	3
3. Installation Overview .....	3
4. Wiring .....	4 - 5
5. Operation .....	6
6. Operation Indicators .....	7
7. Programming.....	8
8. Base Settings – All models.....	
<b>F0</b> Basic Parameters .....	9
<b>F2</b> Motor Parameters .....	9
<b>F5</b> Function of DI Terminals .....	10
<b>F7</b> Controller Features .....	10
<b>FA</b> Alarm and Protection .....	10
<b>FD</b> Specific Solar Pump Controller Parameters .....	11
<b>FF</b> Group Factory Parameters .....	11
<b>Base Programming: One-page summary</b> .....	12
9. Quick Config #1: 230V – Pressure switch .....	13
10. Quick Config #2: 415V – Pressure switch .....	14
11. Quick Config #3: Kelco F29 Flow Sensor .....	14
12. Quick Config #4: 4-20mA Pressure Transducer.....	15
13. Quick Config #5: No inputs (power stop / start).....	15
14. Addressing common errors .....	16

## 2. Range Introduction

### **BIA-NXT-FLEXISOLAR-22: PN 811612**

AC Input = 230V 1~ AC OR DC Input – *Single string solar input*  
Output Power = Up to 2200W (230V Single Ph/230V Three Ph)  
Rated Amps = 9.6A

### **BIA-NXT-FLEXISOLAR-40: PN 811613**

AC Input = 415V 3~ AC OR DC Input – *Single string solar input*  
Output Power = Up to 4000W (415V Three Ph)  
Rated Amps = 9.0A

### **BIA-NXT-FLEXISOLAR-75: PN 811614**

AC Input = 415V 3~ AC OR DC Input – *Single or Dual string solar input*  
Output Power = Up to 7500W (415V Three Ph)  
Rated Amps = 17.0A

## 3. Installation Overview

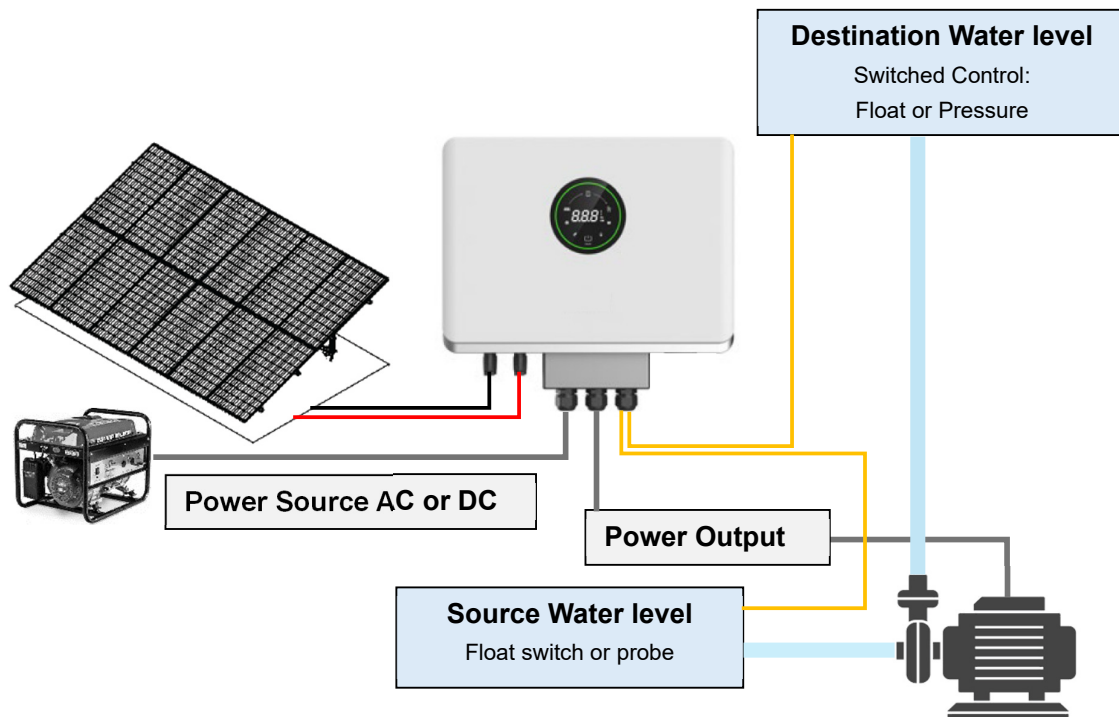

## 4. Wiring

Symbol	Name	Technical Specifications
R/L, S, T/N	AC INPUT Terminals	R/L and T/N for single phase 230V input R/L, S and T/N for 3 phase 415V input
PE	Ground Terminal	Power Input and Motor Output ground terminal
U,V,W	AC OUTPUT Terminals	The 3-phase pump motor connects to the U/V/W output terminals respectively.
DI1, DI2, DI3	Multi-functional Digital Input Terminals	Optocoupler isolated unidirectional input ON when closed circuit to GND, OFF when open circuit to GND Input voltage range: 9~36VDC Input impedance: 4kΩ
24V	Analog Reference Voltage	24V, ±5%, Maximum output current 100mA
+10V	Analog Reference Voltage	10V, ±5%, Maximum output current 50mA
AI	Analog Input Terminal	Default as 4~20mA input. Can be set to 0-10V input. Default resistance 500Ω.
GND	Analog GND	Reference zero potential of the analog reference voltage.
S+ / S0 / S-	Communication Port for Multi Drive System (CAN Protocol)	Standard CAN communication interface Use twisted pair or shielded wire and connect S+, S0, S- when building multi-drive systems



## 4. Wiring Cont.

### Switched Inputs

#### Software Update from Serial Number 4016 onwards

Flexi Solar now accepts 4-20mA Transducer input

Default now for NC floats/ switches etc. (No need to change F5.25 setting unless using a reverse acting pressure switch)

#### Pre Serial Number 4016

Units do not support 4-20mA Transducer input

Default setting assume NO floats/ (reverse acting) pressure switches.

F5.25 setting can be altered to accept 'normal' pressure switches (opens at high pressure / closes at low pressure)

---

---

### Single Phase AC Input Power Wiring (Incl. Generator)

Remove the junction box in the middle of controller bottom.

Pass the AC input wire through the cable gland.

- Connect input single-phase AC to the R/L and T/N terminals. Ground wire to PE

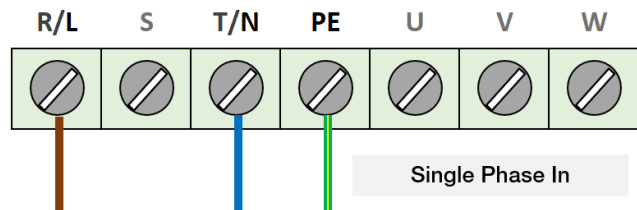

### Three Phase AC Input Power Wiring (Incl. Generator)

Remove the junction box in the middle of controller bottom.

Pass the AC input wire through the cable gland.

- Connect three-phase AC to the R/L and S and T/N terminal. Connect ground wire to PE.

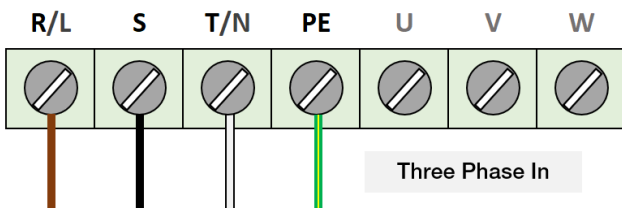

### Motor Wiring

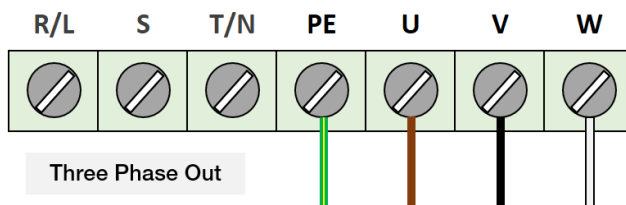

Connect 4 cables from the motor to the U, V, W, PE terminals of the controller through the water-resistant gland on the junction box.

## 5. Operation

Using the display screen, the controller can be stopped or started its working status can be monitored. Programming is achieved using an external keypad.













Controller programming cannot be accessed via the main display



### Run Modes



## 6. Operation Indicators

Icon	Name	Function
	Controller State Indicator	The colour and behaviours of the outer ring provides a clear indication of the Controller Status
	Solar Array Indicator	This icon displays in the 10 o'clock position when there is a DC power input
	Input Power Indicator	This icon displays in the 12 o'clock position when the controller is powered on
	Pump Indicator	This icon displays in the 2 o'clock position when the controller is able to run the pump
	Communication Indicator	When this indicator displays, it means that the GPRS module is connected, and the communication is successful. If it is flashing, it means that the communication has failed. When it is off, it means that the GPRS module is disconnected.
	Multi-Drive Indicator	This icon will only display if the controller has been configured for Multi-Drive mode. The icon does not indicate that communication is occurring, only that the controller is configured as Multi-Drive
	Low Level indicator (source)	Requires a Low-level probe or float installed at the source. When the source water level is too low, the low-level indicator and the LOU water shortage fault will display;
	Tank full indicator (destination)	Requires a float or pressure switch installed to control water delivery to the destination. When switch indicated that no more water is required, the controller tank full indicator will light up, and FUL will be displayed
	Stop Start button	In the working state, <b>Press and Hold for 3 seconds to start or stop the controller.</b> Short press will scroll through the 4 main running state parameters (see below)
	Output Current	Controller output current in Amps
	Bus Voltage	Inner bus voltage (a DC voltage value equal to input DC voltage, OR input AC voltage multiplied by 1.414)
	Running Frequency	Pump running frequency in Hertz
	Output Power	Controller output power i.e. pump (P1 value)

# 7. Programming

Control the pump. Inactive when in the programming menus.

LED illuminates indicating error(s)

Increase or decrease values using the rotary knob or buttons.

Enters and Exits the programming menus.

There are three levels of menus,  
 L1 • Parameter Group i.e. F1  
 L2 • Parameter number within its group i.e. F1.01  
 L3 • Parameter set value

ENT to accept the value and progress to the next parameter. To exit and move up a level without change, press PRG.

- Standby state – displays bus voltage
- Run state: Scrolls Hz / Amps / Bus Voltage / Output
- L1 programming menu: Scrolls F0 / D0 / E0
- L2 programming: Scrolls Hundreds / Tens / Ones
- L3 programming: Scrolls Hundreds / Tens / Ones

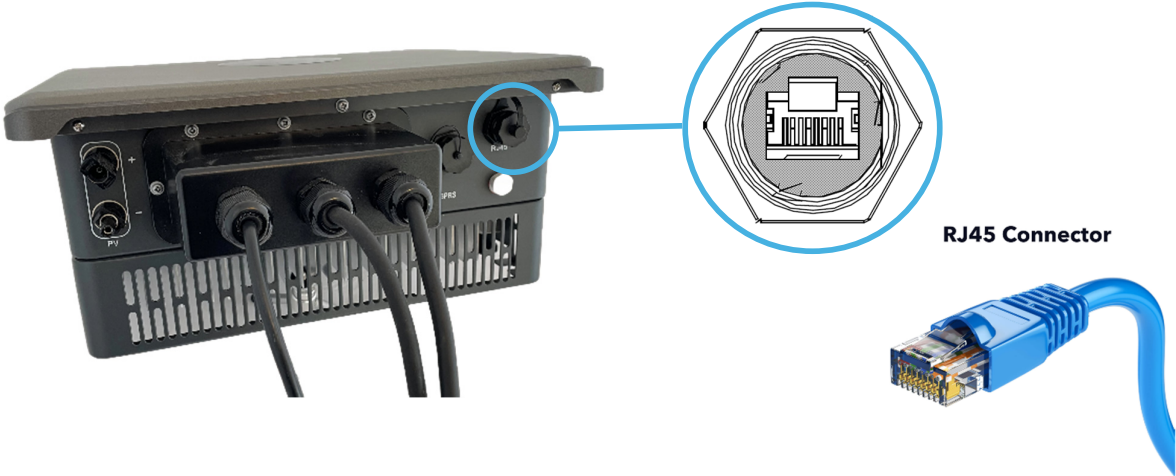

## 8. Base Settings – All models



Parameter can be altered whether the controller is stopped or running.



Controller must be stopped to change parameter.



Measured value or a manufacturer's default which cannot be changed.

### F0 Basic Parameters

Address	Name	Setting Range	Default	Remarks		Comms Address
F0.09	Motor Rotation Direction	0 : FWD 1 : REV	0			0x009
F0.10	Maximum Output Frequency	50.00 ~ 320.00Hz	50.00Hz	Do not exceed motor rated frequency		0x00A
F0.12	Upper Limit of Running Frequency	F0.14 to F0.10	50.00Hz	System maximum speed		0x00C
F0.18	Acceleration Time1	0.0 ~ 6500.0s * 1 sec for Bore Pump * 5 sec for Surface Pump	Model Dependent			0x012
F0.19	Deceleration Time1	0.0 ~ 6500.0s * 1 sec for Bore Pump * 5 sec for Surface Pump	Model Dependent			0x013

### F2 Motor Parameters

Address	Name	Setting Range	Default	Remarks		Comms Address
F2.00	Type of Motor	0: 3 Ph Asynchronous Motor (AM) 1: 3 Ph Permanent Magnet Synchronous Motor (PMSM) 2: Single Phase AM Motor	0			0x200
F2.01	Motor Rated Power	0.4 - 11kW	Varies according to the Controller Model	F2.00~F2.06 must be set according to motor nameplate 		0x201
F2.02	Motor Rated Voltage	1 - 480V				0x202
F2.03	Motor Rated Current	0.1 - 50.0A				0x203
F2.04	Motor Rated Frequency	As per F0.10				0x204
F2.05	Motor Rated Speed	1- 65000rpm				0x205
F2.06	Quantity of Poles	2 ~ 48 2 pole = approx. 2900rpm 4 pole = approx. 1450 rpm				

## F5 Function of DI Terminals

Address	Name	Setting Range	Default	Remarks		Comms Address
F5.21	DI1 Open Delay	0.0 – 360 sec	1.0	Terminal Contact detection time		0x515
F5.23	DI1 Close Delay	0.0 – 360 sec	1.0			0x518
F5.25	DI Logic	0 = High level (open) 1 = Low level (closed)	0x0000	Reverses logic of input circuit		0x519
F5.31	Terminal Control Option	<b>Ones Digit:</b> <i>Recovery Mode of Free Stop Terminal</i> 0: Recover Running after Disabled 1: Don't Recover Running after Disabled <b>Tens Digit:</b> <i>Recover Mode of Emergency Stop Terminal</i> 0: Recover Running after Disabled 1: Don't Recover Running after Disabled <b>Hundreds Digit:</b> <i>Terminal Start Option after Alarm Reset</i> 0: Can Directly Start 1: Must Stop First <b>Thousands Digit:</b> <i>Reserved</i>	0x0011			0x51F

## F7 Controller Features

Address	Name	Setting Range	Default	Remarks		Comms Address
F7.10	<b>To unlock and display parameter groups FA, FB and FC supplementary menus set F7.10 = 0</b> <b>Note: Parameter FA.08 needs altered when powering a single phase pump</b>					

## FA Alarm and Protection

Address	Name	Setting Range	Default	Remarks		Comms Address
FA.08	Phase Loss protection	Binary Expression: 	0x0011	When connected to a single phase pump: Set <b>FA.08 = 0010</b> to deactivate loss of phase protection		0xA08
FA.20	Fault self recovery times	0 - 30	<b>Set to 30</b>	Select 1 to 5 to enable automatic fault reset operation. When there is a fault during operation, the fault will be reset automatically after fixing for 10S.		0xA14
Water shortage, disconnection, high and/or low voltage, pipe burst, external fault, time arrival fault are not affected by function code FA.20						

## FD Specific Solar Pump Controller Parameters



**FD Group is critical to Solar Operation**

Address	Name	Setting Range	Default	Remarks		Comms Address
FD.01	Running mode option	0: PV Input Mode 1: PV Priority Mode 2: Power Priority Mode	1			0xD00
0: PV input refers to only PV DC power supply (No AC input) 1: PV priority mode means that when AC and DC input power are both connected at the same time, the PV power will be used first, and the AC will be automatically connected when the PV power is insufficient. 2: Power priority mode, when AC and DC input are both connected at the same time, real-time power complementation ensures maximum power output.						
FD.07	Weak light detection time	0.0sec – 1000.0sec	100.0sec			0xD06
FD.08	Weak light restart time	0.0sec – 3600.0sec	300.0 sec			0xD07
FD.10	MPPT VOC	250.0V – 800.0V	750.0V	Set to array VOC		0xD09
FD.14	Software Dry Run Detection Delay	0.0 sec – 3600.0 sec	20.0 sec			0xD0D
FD.15	Water shortage detection frequency	0.0% - 100.0%	90.0%			0xD0E
FD.16	Software Dry Run Detection Current Percentage	0.0% – 100.0% of Motor Rated Current	40.00%			0xD0F
FD.17	Dry Run Restart Delay	0 min – 9000 min				0xD10

## FF Group Factory Parameters

FF.02 = **04007** → Enter Password: If the last 4 digits of the serial number is 4005  
 or **04017** → Enter Password: If the last 4 digits of the serial number is 4016

Only input these settings after a firmware update has been performed

FF.02 = XXX      VFD Power code after firmware update

Power	Voltage	FF.02
2.2kW	230V	203
2.2kW	415V	003
4kW	415V	005
7.5kW	415V	007

# Base Programming: One-page summary

## FLEXISOLAR PROGRAMMING

### SETTINGS

### NOTES

FF.02 = <b>04007</b>	→	Enter Password: If the last 4 digits of the serial number is 4005															
or <b>04017</b>	→	Enter Password: If the last 4 digits of the serial number is 4016															
FF.02 = <b>XXX</b>		VFD Power code after firmware update															
<p style="color: red; text-align: center;">Only input these settings after a firmware update has been performed</p>		<table border="1"> <thead> <tr> <th>Power</th> <th>Voltage</th> <th>FF.02</th> </tr> </thead> <tbody> <tr> <td>2.2kW</td> <td>230V</td> <td><b>203</b></td> </tr> <tr> <td>2.2kW</td> <td>415V</td> <td><b>003</b></td> </tr> <tr> <td>4kW</td> <td>415V</td> <td><b>005</b></td> </tr> <tr> <td>7.5kW</td> <td>415V</td> <td><b>007</b></td> </tr> </tbody> </table>	Power	Voltage	FF.02	2.2kW	230V	<b>203</b>	2.2kW	415V	<b>003</b>	4kW	415V	<b>005</b>	7.5kW	415V	<b>007</b>
		Power	Voltage	FF.02													
		2.2kW	230V	<b>203</b>													
		2.2kW	415V	<b>003</b>													
		4kW	415V	<b>005</b>													
7.5kW	415V	<b>007</b>															

1	F0.10 = 50	Max Output frequency
2	F0.12 = 50	Upper limit of running frequency
3	F0.18 = Set according to pump type	Acceleration time in seconds* *1 sec for Bore Pump *5 sec for Surface Pump
4	F0.19 = Set according to pump type	Deceleration time in seconds* *1 sec for Bore Pump *5 sec for Surface Pump
5	F2.00 = Set according to motor type	0 : Ordinary 3 Phase Asynchronous Motor(AM) 1 : Permanent Magnetic Synchronous Motor(PMSM) 2 : Single Phase Asynchronous Motor
6	F2.01 = Name plate value	Motor rated power
7	F2.02 = Name plate value	Motor rated voltage
8	F2.03 = Name plate value	Motor rated current
9	F2.04 = Name plate value	Motor rated freq.
10	F2.05 = Name plate value	Motor rated rpm
11	F2.06 = According to motor	No. of poles
12	F5.21 = 360	Error reset time in secs (1 of 2)
13	F5.23 = 360	Error reset time in secs (2 of 2)
14	F5.31 = According to system setup	Terminal control
15	F7.10 = 0	To unhide FA, FB, FC settings
16	FA.20 = 30	Error self recovery times
17	FA.08 = 0010	Cancels loss of phase detection   Only applicable for 230V 1phase motors
18	FD.01 = 1*	PV Priority mode * 0 : Solar Only Mode 1 : Solar Priority Mode 2 : AC Priority Mode <i>*If running only on DC: set to 0 = PV Input Mode</i>
19	FD.07 = 10	Low light detection time in sec
20	FD.08 = 180	Low light restart time in sec
21	FD.10 = Array VOC	MPPT VOC. Read VOC voltage from solar panel lable. Calculate total Array VOC and input
22	FD.20 = 60	Lower limit MPPT output frequency
23	FD.14 = 20	Dry run detection time in seconds
24	FD.15 = 90	Dry run detection frequency in %
25	FD.16 = 40	Dry run detection current in %
26	FD.17 = 30	Dry run restart delay in minutes

These values are default settings but can be adjusted

### Dual Voltage 3 Phase Motors

Ensure the terminal links are correctly configured.

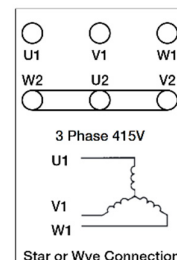
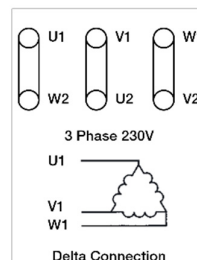

## 9. Quick Config #1: 230V – Pressure switch

230V 1ph INPUT / 230V 3ph OUTPUT >>>



**FlexiSolar22**  
DC Input:  
Single string to max 450V

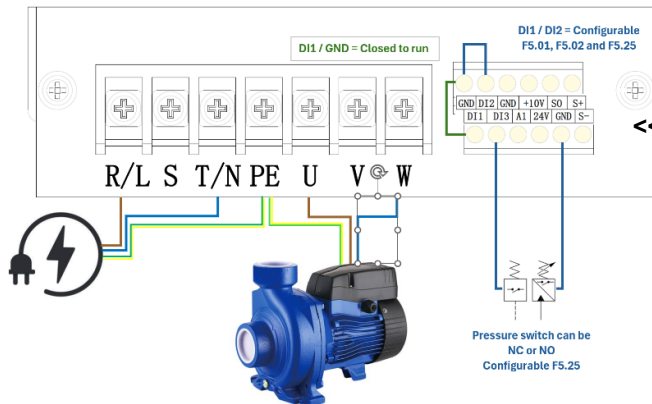
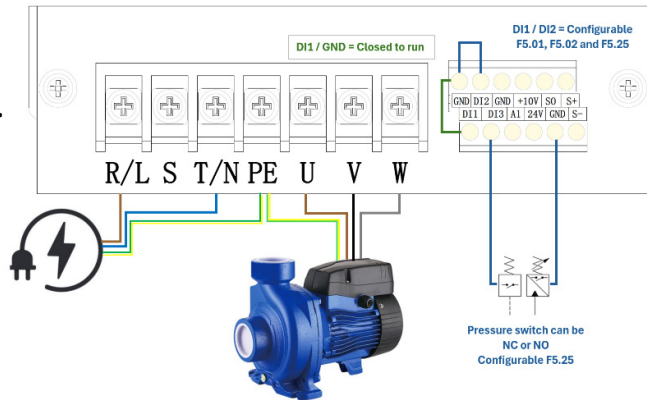

<<< 230V 1ph INPUT / 230V 1ph OUTPUT

Address	Name	Setting Range	SETTING	NOTES
F0.01	Start/Stop Source Option	0: Start/Stop Button 1: Terminal (Flexi -Solar) 2: RS485 Communication	1	Default is terminal (controller) Alternatives are RS485 signal or remote stop/start button
F5.00	DI1 Function	0 : No Option 1 : FWD Running (FWD) 4 : FWD Jog (FJOG)	1 Always	D1 / GND = Closed to run
F5.01	DI2 Function	9 : Error Reset (RESET) 11 : External Alarm (NO signal) input	47	DI2 and Di2 can be used for NC or NO switch or float Tune F5.25 accordingly
F5.02	DI3 Function	47 : Well Low Level Input 48 : Water Tank Full Input	48	
F5.25	DI Logic	0 = High level (open) 1 = Low level (closed)	0 is default	Reverses logic of input circuit if necessary
F5.31	Function of DI terminals to start/stop the motor		0011	
FA.20	Fault self recovery times		5	Default is 3

## 10. Quick Config #2: 415V – Pressure switch

415V 1ph INPUT / 415V 3ph OUTPUT >>>

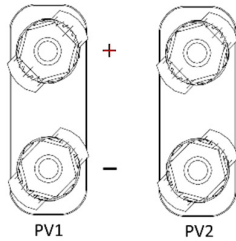

**FlexiSolar40**  
DC Input:  
Single string to max 800V

**FlexiSolar75**  
DC Input:  
Single or Dual string  
to max 800V

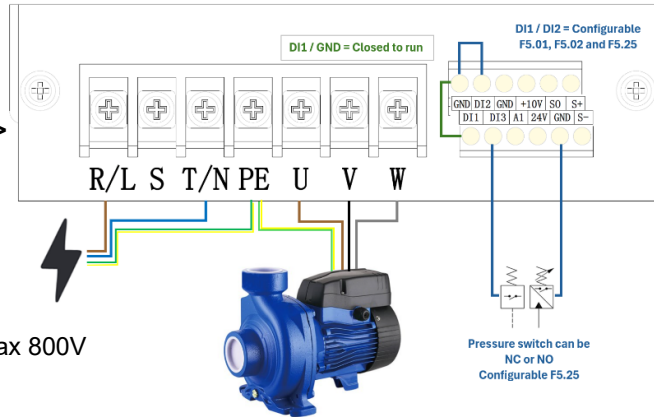

Address	Name	Setting Range	SETTING	NOTES
F0.01	Start/Stop Source Option	0: Start/Stop Button <b>1: Terminal (Flexi -Solar)</b> 2: RS485 Communication	1	Default is terminal (controller) Alternatives are RS485 signal or remote stop/start button
F5.00	DI1 Function	0 : No Option <b>1 : FWD Running (FWD)</b> 4 : FWD Jog (FJOG)	<b>1</b> Always	<b>DI1 / GND = Closed to run</b>
F5.01	DI2 Function	9 : Error Reset (RESET) 11 : External Alarm (NO signal) input	47	DI2 and DI2 can be used for NC or NO switch or float Tune F5.25 accordingly
F5.02	DI3 Function	47 : Well Low Level Input 48 : Water Tank Full Input	48	
F5.25	DI Logic	0 = High level (open) 1 = Low level (closed)	0 is default	Reverses logic of input circuit if necessary
F5.31	Function of DI terminals to start/stop the motor		0011	
FA.20	Fault self recovery times		5	Default is 3

## 11. Quick Config #3: Kelco F29 Flow Sensor

Wire according to the diagram. >>>

Address	Value
F0.01	<b>1 - Always</b>
F5.00	1
F5.01	47
F5.02	48 (No flow = off)
F5.25	0 is default
F5.31	0011
FA.20	5

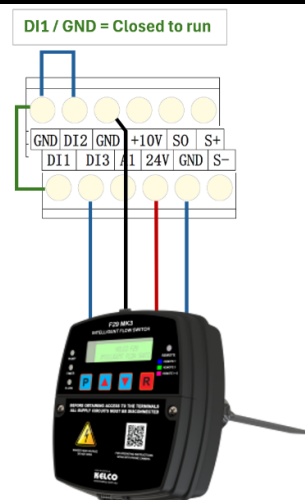

## 12. Quick Config #4: 4-20mA Pressure Transducer

Wire according to the diagram. >>>

Note: DI terminals can be employed in conjunction with 4-20mA transducer

Address	Value
F0.01	1
F5.00	1
F5.01	47
F5.02	48
F5.25	0 is default
F5.31	0011
FA.20	5

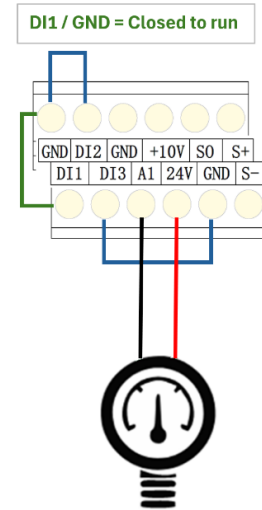

Address	Name	Setting Range	SETTING	NOTES
FD.27	Pressure Transmitter Range	0.0 bar – 200.0 bar	16.0 bar	<i>Default is terminal (controller) Alternatives are RS485 signal or remote stop/start button</i>
FD.40	Cut In Pressure	In Bar	As required	
FD.41	Cut Out Pressure	In Bar	As required	
FD.42	Set to 1 to enable Pressure Transducer Function.			

## 13. Quick Config #5: No inputs (power stop / start)

Wire according to the diagram. >>>

Address	Value
F0.01	1
F5.00	1
F5.01	47
F5.02	48
F5.25	0 is default
F5.31	0011

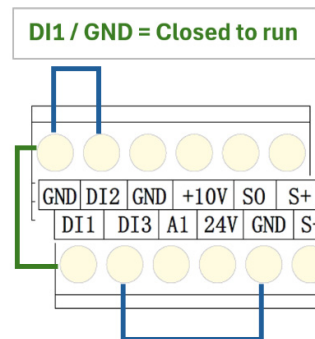

## 14. Addressing common errors

### E05 – Over voltage during acceleration

- Normally due to rapid acceleration of motor.
- Adjust acceleration speed
  - Bore motors 2 -3 seconds
  - Others 5 – 8 Seconds s
- Input voltage could be too high – check panels

### E06 – Over voltage during deceleration

- Normally due to rapid deceleration of motor.
- Adjust deceleration speed
  - Bore motors 2 - 3 seconds
  - Others 5 – 8 Seconds
- Input voltage could be too high – check panels

### E07 – Over voltage during constant running

- Input voltage could be too high – check panels
- Could be combination of higher output panels and voltage boosting on 2.2kw model. Voltage booster can be disabled

### E09 – Low input voltage

- Not enough panels for motor to start, or bad connections

## Controller Error Codes

E02 : Overcurrent during acceleration  
E03 : Overcurrent during deceleration  
E04 : Overcurrent at constant speed  
E05 : Overvoltage during acceleration  
E06 : Overvoltage during deceleration  
E07 : Overvoltage at constant speed  
E08 : Snubber resistor overload  
E09 : Low input voltage  
E10 : Controller overload  
E11 : Motor overload  
E12 : Input phase loss  
E13 : Output phase loss  
E14 : IGBT overheat  
E15 : External alarm input  
E16 : Communication failure  
E17 : Snubber relay failure  
E18 : Current detection failure

E19 : Motor tuning failure  
E20 : Reserved  
E21 : Parameter R/W failure  
E22 : EEPROM failure  
E23 : Motor short to ground  
E24 : Dry run alarm  
E25 : Reserved  
E26 : Running time reached  
E27 : Water shortage  
E28 : Reserved  
E29 : Power-on time reached  
E30 : Load loss  
E40 : Fast current limit timeout failure

E98, E99:  
Communication failure between controller and external keypad



**[www.whiteint.com.au](http://www.whiteint.com.au)**

**[www.whiteint.co.nz](http://www.whiteint.co.nz)**

**Please always refer to our website for further technical information & new product innovations**

**Disclaimer:** Every effort has been made to publish the correct information in this manual. No responsibility will be taken for errors, omissions or changes in product specifications.

© 2026 Copyright White International Pty Ltd

TM ® - WARNING: Please be aware that various brands & products depicted within this document are subject to trademark, patent or design registrations. Infringement of any intellectual property contained within this document without express written authority by the appropriate intellectual property holder may result in further legal action to be taken. For any queries regarding use of the contained information please feel free to contact White International Pty Ltd.